

NEU: Wandwinden mit Schneckengetriebe

GEHOERE
Hebezeuge

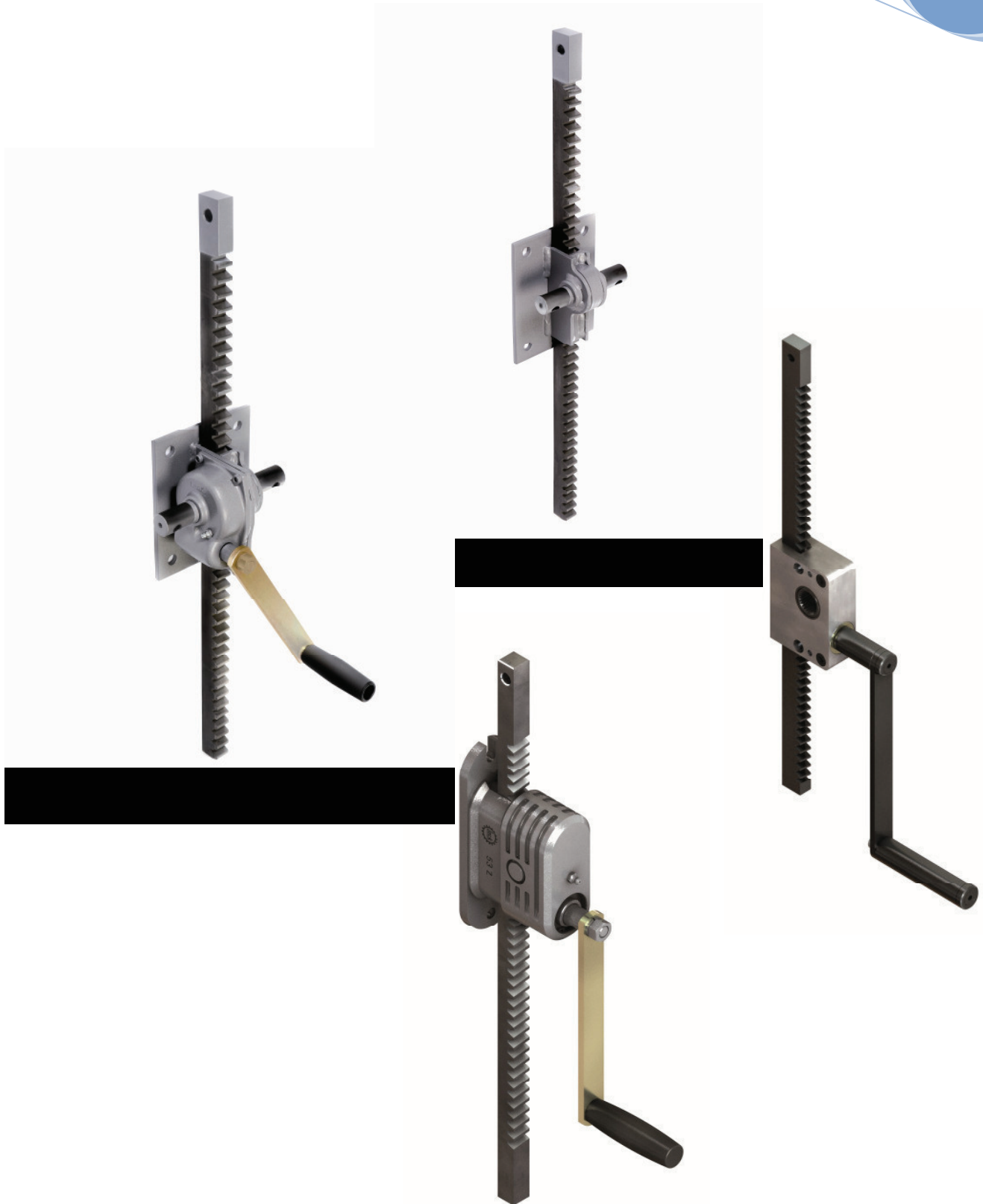

Gebr. Hönscheid e.K.
Winden-und Hebezeugfabrik

Brüderstrasse 17 - 19
51588 Nümbrecht

www.gehoere.de
info@gehoere.de
Tel. ++49 (0) 22 93 / 81 65 79 - 0
Fax. ++49 (0) 22 93 / 81 65 79 - 9

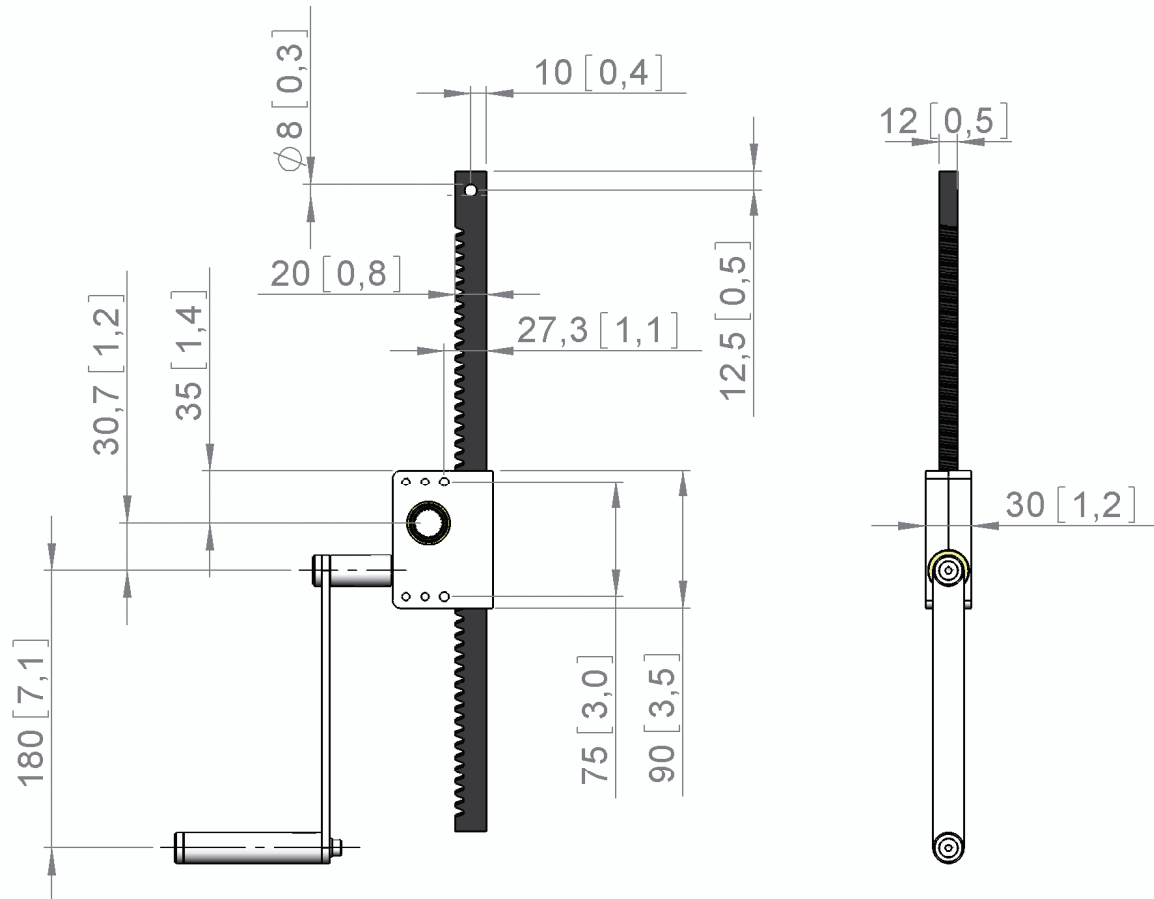

Typ	Art.-Nr.:	F [N]	H[mm]	Hub / Umdrehung	F _{Hand}	m [kg]
HZW 45.0110	51145.0110.03	1000	270	7,85mm	75N	1,3
HZW 45.0111	51145.0111.03	1000	270			1,1

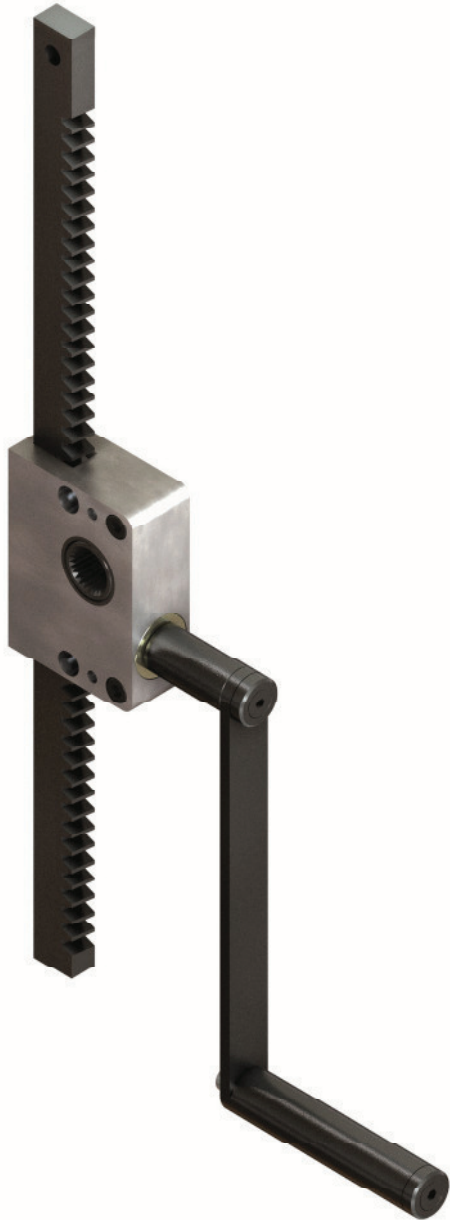

Produktbeschreibung

Gefrästes, selbsthemmendes Schneckengetriebe. Spezialgehäuse. Getriebe und Zahnstange aus Stahl, Verschleißteile gehärtet. Robuste Präzisionsausführung.

Auf Zug und Druck belastbar. Schneckenlager aus Bronze, Zahnstangenführungen mit Gleitkunststoff.

Standard – Hublänge 270 mm. Andere Hublängen bieten wir gerne an. (max. 500 mm)

1000N Gesamtlast

Product description

Machined, self – locking gear unit. Special housing. Gear unit and gear rack are made of steel. Wearing parts hardened. Robust precision design.

Loadable in tension and compression. Bronze screw bearings. Gear rack guide with plastic slides.

Standard stroke length 270 mm. Additional stroke length on demand. (max. 500 mm)

1000N total load



Produktbeschreibung

Gefrästes, selbsthemmendes Schneckengetriebe. Spezialgussgehäuse. Getriebe und Zahnstange aus Stahl, Verschleißteile gehärtet. Robuste Präzisionsausführung.

Auf Zug und Druck belastbar. Schneckenlager aus Bronze, Zahnstangenführungen mit Gleitkunststoff.

Standard – Hublänge 400 - 1400 mm. Mehrhub 200 mm gestaffelt möglich.

2500 N o. 5000 N Gesamtlast

Product description

Machined, self – locking gear unit. Special cast iron housing. Gear unit and gear rack are made of steel. Wearing parts hardened. Robust precision design.

Loadable in tension and compression. Bronze screw bearings. Gear rack guide with plastic slides.

Standard stroke length 400 – 1400 mm. Additional stroke in steps of 200 mm.

2500 N or 5000 N total load

Zahnstangenwandwinde HZW 53 (2500-5000 N)

GEHOERE
Hebezeuge

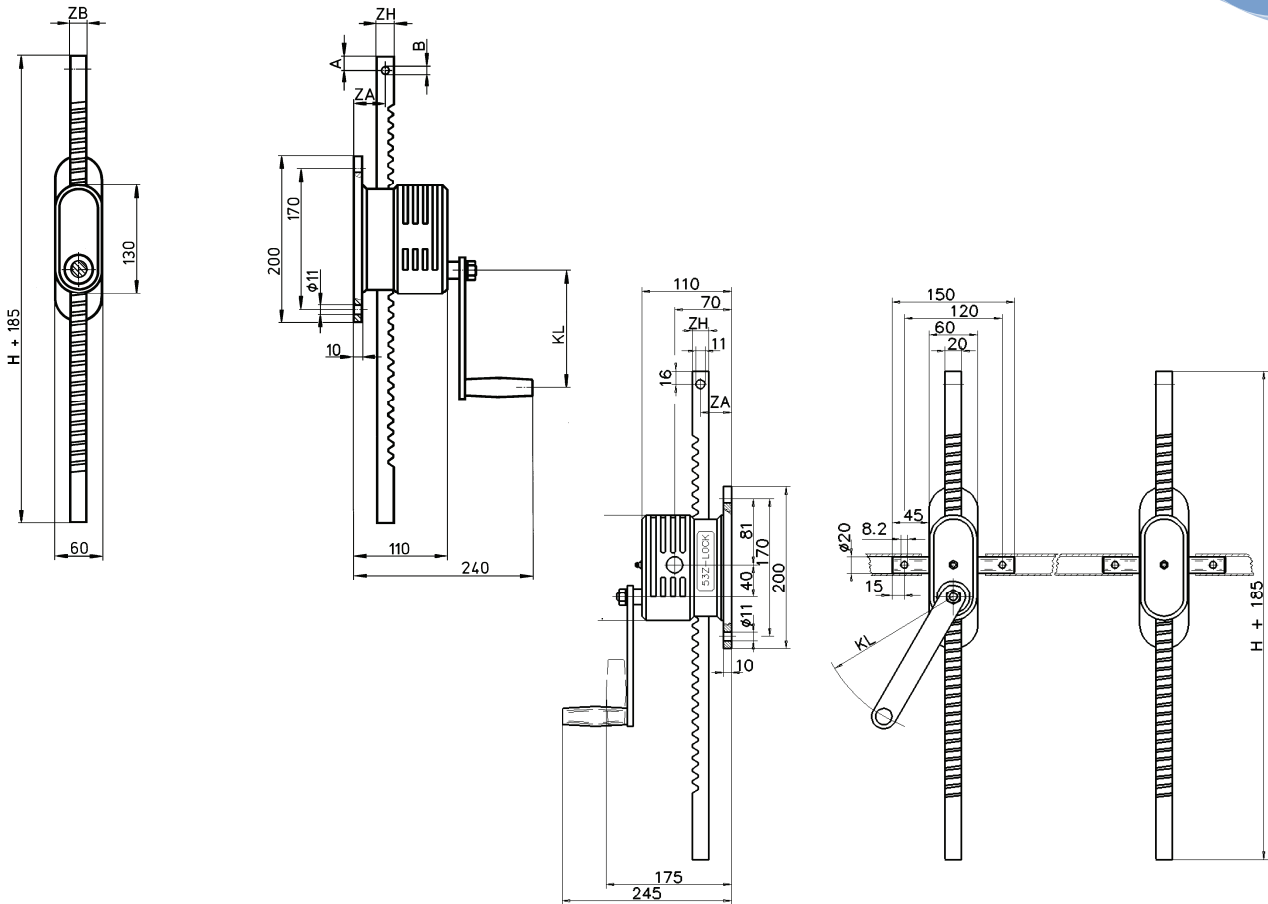

Type	Art.-Nr.:	F [N]	Hub [mm]	H _K [mm/n]	A	B	KL	ZA	ZB	ZH	m [kg]
HZW53.0204	51153.0201.04	2500	400	11	16	11	200	38	20	20	5,4
HZW53.0206	51153.0201.06		600								5,9
HZW53.0208	51153.0201.08		800								6,4
HZW53.0210	51153.0201.10		1000								6,9
HZW53.0212	51153.0201.12		1200								7,4
HZW53.0504	51153.0501.04	5000	400	11	20	13	250	35	20	25	6,0
HZW53.0506	51153.0501.06		600								6,5
HZW53.0508	51153.0501.08		800								7,0
HZW53.0510	51153.0501.10		1000								7,5
HZW53.0512	51153.0501.12		1200								8,0
HZW53.ZWmK	51153.0210.06	2500	600	11	16	11	200	38	20	20	5,9
HZW53.ZWoK	51153.0211.06		600								5,4

Gebr. Hönscheid e.K.
Winden-und Hebezeugfabrik

Brüderstraße 17 - 19
51588 Nümbrecht

www.gehoere.de
info@gehoere.de
Tel. ++49 (0) 22 93 / 81 65 79 - 0
Fax. ++49 (0) 22 93 / 81 65 79 - 9

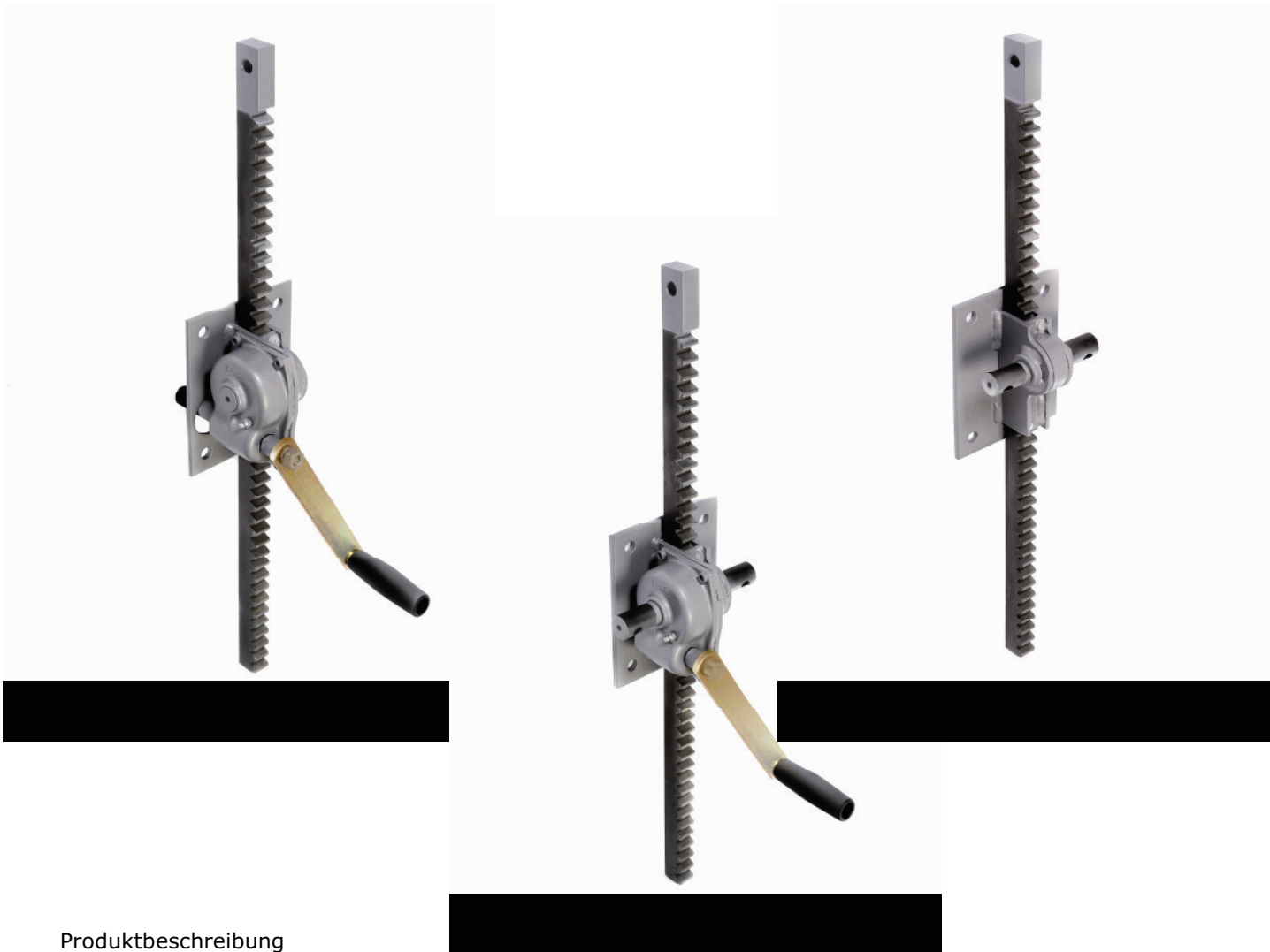

Produktbeschreibung

Gefrästes, selbsthemmendes Schneckengetriebe mit Zahnstangenritzel. Gehäuse aus Spezial-Guss und Stahl. Getriebe und Zahnstange aus Stahl. Bei 51352 Schneckenrad aus Bronze. Verschleißteile gehärtet.

Auf Zug und Druck belastbar.

Standard – Hublänge 600 - 1400 mm. Mehrhub 200 mm gestaffelt möglich.

Summe der Zug- und Druckkraft bei zusammengekuppelten Winden max. 5000 N bzw. 10000 N.

5000 N o. 10000 N Gesamtlast

■ Zahnstange wird lose mitgeliefert ■

Product description

Machined, self-locking worm gear unit, with gear rack pinion. Housing of special cast iron and steel. Gear unit and gear rack of steel, worm wheel of 51352 of bronze, wearing parts hardened.

Loadable in tension and compression.

Standard stroke length 600 – 1400 mm. Additional stroke in steps of 200 mm.

Total of tension or compression load with winches coupled: max. 5000 N or 10000 N.

5000 N or 10000 N total load

■ Rack is delivered separately ■

Gebr. Hönscheid e.K.
Winden-und Hebezeugfabrik

Brüderstraße 17 - 19
51588 Nümbrecht

www.gehoere.de
info@gehoere.de
Tel. ++49 (0) 22 93 / 81 65 79 - 0
Fax. ++49 (0) 22 93 / 81 65 79 - 9

Zahnstangenwandwinde HZW 51 (5000-10000 N)

GEHOERE
Hebezeuge

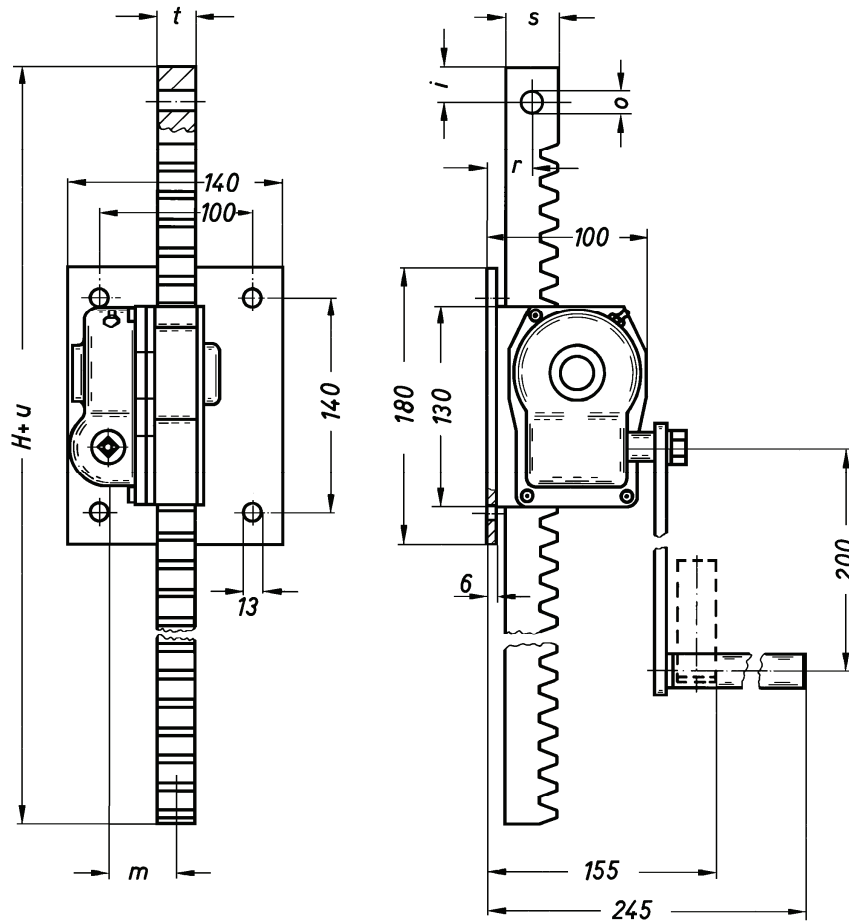

Type	Art.-Nr.:	F [N]	Hub [mm]	H _k [mm/n]	i	m	o	r	s	t	u	m [kg]
HZW51.0500	51351.0501.00	5000	---	5,2	20	40	13	25	30	20	120	4,7
HZZ 51.0506	51351.0597.06		600									2,8
HZZ 51.0508	51351.0597.08		800									3,5
HZZ 51.0510	51351.0597.10		1000									4,3
HZZ 51.0512	51351.0597.12		1200									5,1
HZZ 51.0514	51351.0597.14		1400									5,8
HZW52.1000	51352.1001.00	10000	---	3,6	22	43	16	30	35	25	140	4,8
HZZ 52.1006	51352.1097.06		600									4,1
HZZ 52.1008	51352.1097.08		800									5,2
HZZ 52.1010	51352.1097.10		1000									6,3
HZZ 52.1012	51352.1097.12		1200									7,3
HZZ 52.1014	51352.1097.14		1400									8,4

Gebr. Hönscheid e.K.
Winden-und Hebezeugfabrik

Brüderstraße 17 - 19
51588 Nümbrecht

www.gehoere.de
info@gehoere.de
Tel. ++49 (0) 22 93 / 81 65 79 - 0
Fax. ++49 (0) 22 93 / 81 65 79 - 9

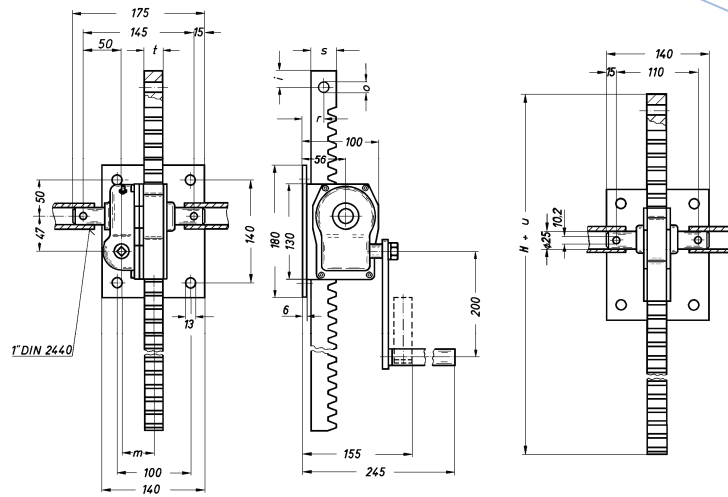

ZWmK

ZWoK

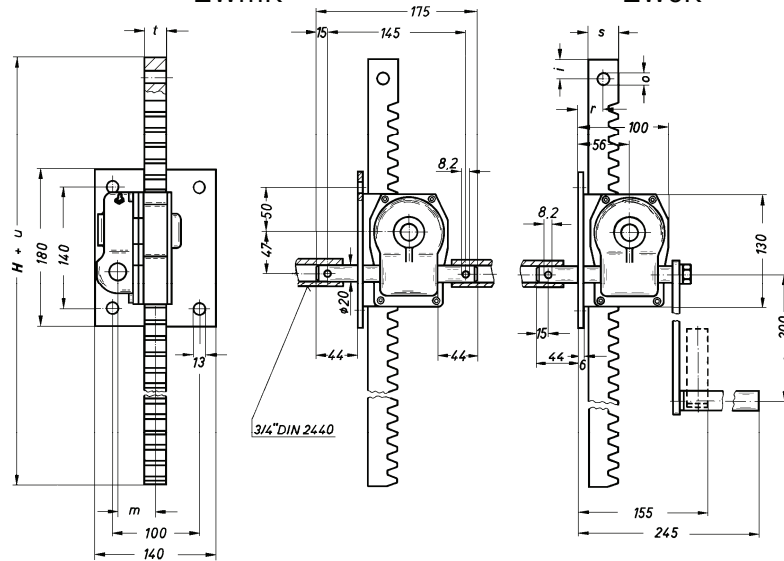
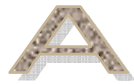

Avb

Ard

AvK

Type	Art.-Nr.:	F [N]	Hub [mm]	H _k [mm/n]	i	m	o	r	s	t	u	m [kg]
HZW 51.ZWmK	51351.0510.00	5000	---	5,2	20	40	13	25	30	20	120	5,2
HZW 52.ZWmk	51352.1010.00	10000	---	3,6	22	43	16	30	35	25	140	5,1
HZW 51.ZWoK	51351.0511.00	---	---	---	20	---	13	25	30	20	120	2,8
HZW 52.ZWoK	51352.1011.00	---	---	---	22	---	16	30	35	25	140	3,0
HZW 51.AvK	51351.0520.00	5000	---	5,2	20	40	13	25	30	20	120	4,9
HZW 52.AvK	51352.1020.00	10000	---	3,6	22	43	16	30	35	25	140	5,0
HZW 51.Avb	51351.0521.00	5000	---	5,2	20	40	13	25	30	20	120	4,3
HZW 52.Avb	51352.1021.00	10000	---	3,6	22	43	16	30	35	25	140	4,4
HZW 51.Ard	51351.0522.00	5000	---	5,2	20	40	13	25	30	20	120	4,1
HZW 52.Ard	51253.1022.00	10000	---	3,6	22	43	16	30	35	25	140	4,2

Gebr. Hönscheid e.K.
Winden-und Hebezeugfabrik

Brüderstraße 17 - 19
51588 Nümbrecht

www.gehoere.de
info@gehoere.de
Tel. ++49 (0) 22 93 / 81 65 79 - 0
Fax. ++49 (0) 22 93 / 81 65 79 - 9